

RUBBER KEYPAD DESIGN GUIDE

2024



HMI Components Division
Diamond Electronics Limited



01477 505206



diamondhmi.co.uk



sales@diamondhmi.co.uk

Index

Introduction to Rubber Keypads	3
Silicone Rubber: Material Breakdown	4, 5
Features of Silicone Rubber Keypads	5
Specific Characteristics	6
Basic Key Design	6
Finishes	7
Design Considerations	7
Snap Ratio	7, 8
Tactile Feedback	8
Switch Life	9
Minimum Key Height	9
Conductive Switch Contacts	9, 10
Annular Shaped Conductive Pill	10
Metal Switch Domes	11
Polyester Switch Domes	11
Printed Circuit Board Design	11, 12, 13
Alignment Features	13
Dimensional Tolerances	13
Actuation Force	13
Mechanical Drawings	13, 14, 15, 16, 17
Conditions for the design of a Rubber Keypad	17
Example Designs for Rubber Keys	18, 19
Printing	19, 20
Epoxy Coated Keytops	20
Polyurethane/Silicone Coating	20
Plastic Keytops	21
Process Overview	21



Introduction to Rubber Keypads

Thank you for your interest in our Rubber Keypad products. This guide has been designed to offer basic information on rubber technology and to provide some basic design constraints to assist with the development of your new project.

Silicone Rubber Keypads with conductive switch contacts were originally developed for the electronics industry as an economical design alternative to discrete switches. Many years on they are the most widely used form of switch technology mainly due to their reliability, long life, low cost, and multitude of design opportunities.

Diamond Electronics has been involved in the Design, Development and Supply of Rubber Keypads for over 30 years. We provide design support to OEMs in the UK and throughout Europe and the World. With field sales engineers available within the UK, we can respond to enquiries with speed and support to your in-house design team with Rubber Keypads, Rubber Gaskets, Seals, Boots etc. Membrane Keypads, CombiKey, Piezo Electric, Touch Screen and Discrete Switch Solutions.

For additional information contact:

Diamond Electronics Ltd
Diamond HMI Division
Fourways Technology Park
London Road
Smallwood
Nr. Sandbach
Cheshire
CW11 2US
United Kingdom

Tel: +44 (0) 1477 505206
Fax: +44 (0) 1477 500656
Email: sales@diamondhmi.co.uk
www.diamondhmi.co.uk

Silicone Rubber: Material Breakdown

Silicone rubber is a synthetic material which has the structure shown in Fig 1.

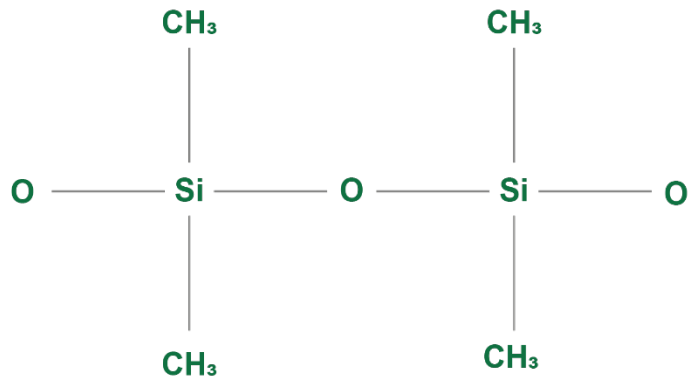
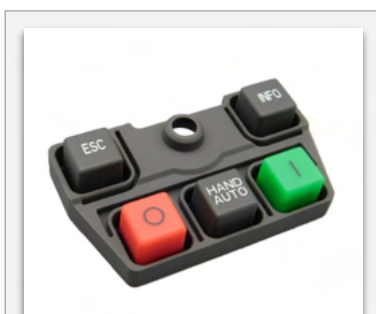

Fig 1 – Structure of silicone rubber

The “Silicone-Oxygen” molecular structure provides characteristics that allow the final material to withstand a wide variety of chemical and mechanical degradation as well as serving as a strong dielectric.

Silicone Rubber possesses the following characteristics:

- Environmental durability with excellent resistance to both heat and low temperature (-55°C ~ +250°C)
- Minimum abrasion and high resistance to SO₂ and oxidation even in heavy humidity
- Minimum chattering or noise generation due to soft and elastic contact structure.



Colour insert moulding with screen printing and clear wear resistive coating

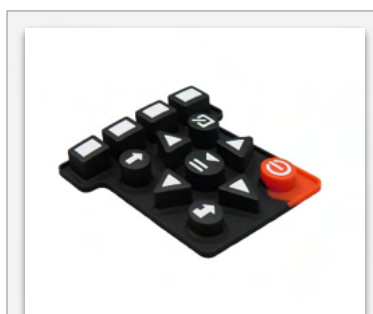

Colour flow moulding with screen printing and clear wear resistant coating

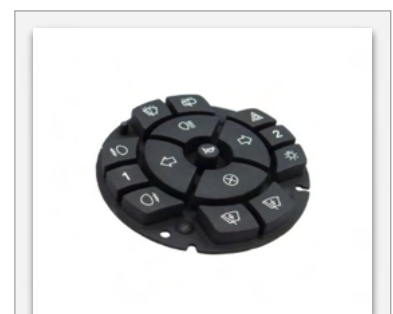

Translucent Silicon spray painted, and laser etched for backlighting with clear wear resistant coating



Screen Printed with epoxy coating



Screen printed hard plastic key caps and clear wear resistive coating



Rubber overlay

*Some examples of different finishes that can be applied can be seen above.

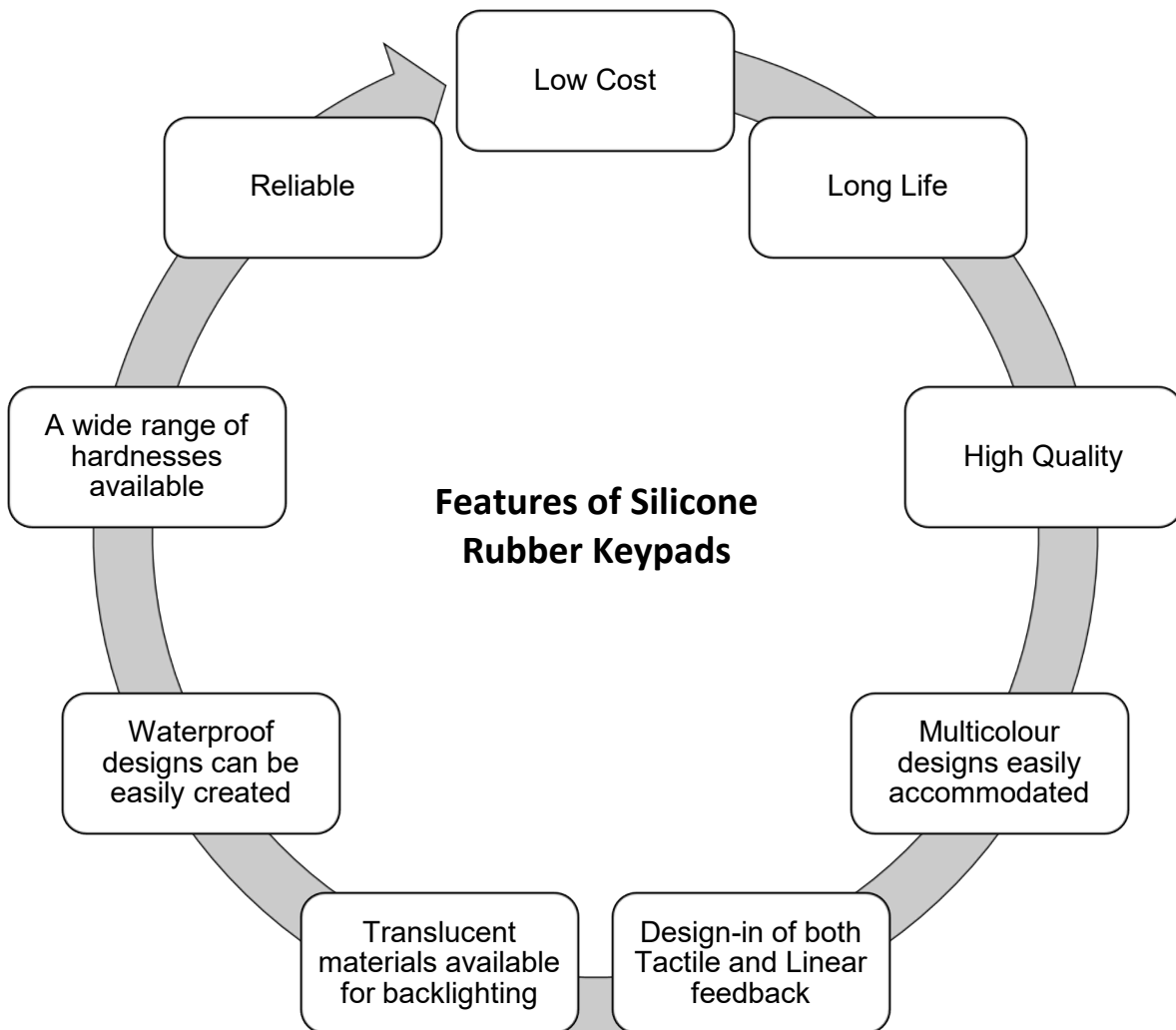

Specific Characteristics

There are a wide range of Silicon materials with varying Hardness from 40 Shore A to 80 Shore A and below shows a table relating to a commonly used 65 Shore A material, used in the manufacture of conductive Silicone Keypads. Additional information on materials with different characteristics to suit specific applications can be obtained by contacting the Diamond HMI Product Support Team.

Characteristics	Characteristics	Characteristics
Hardness (Shore A)	65 ± 5	30 ~ 80 ±
Tensile Strength (Kg/cm ²)	60	65 ~ 85
Tear Strength (Kg/cm)	15	10 ~ 15
Compression Set (%)	20	11 ~ 22
Specific Gravity at 25°C	1.18	1.11 ~ 1.18
After 22 Hrs at 175°C		

Contact Resistance	<2000 @ 12V dc 30mA
Insulation Resistance	>100MΩ @ 250V dc
Max Contact Loading	24V dc 100mA

Strength	20 ~ 25 kv/mm
Constant	26 ~ 35 MHz
Volume Resistance	>2x10¹⁴ (0-cm)

Basic Key Design

INDIVIDUAL KEYS

Key design will vary with the functional and aesthetic requirements of the application. A designer may consider the options detailed in this section, which show alternative key styles and the possibilities for adding colours, legends and backlighting to the design.

The table on page 13 details some traditional applications of Rubber Keypad's with outline specifications. These are meant for guidance only but will offer you an insight into the possibilities available to a designer.

Below is a diagram of a basic key structure:

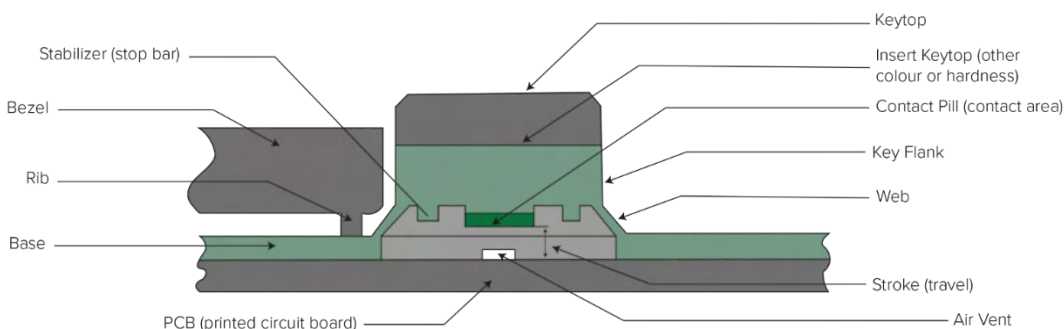

Fig 2 – Basic Key Structure

Finishes

There are various finishes and coverings which can be applied to the surface as follows.

P+R Keytops

Plastic Keytops adhered to the Key surface, these are injection moulded, can be clear or coloured and can be on or under-surface printed, and they have a scratch resistant hard clear coating applied to the surface.

Laser Keytops

Laser Etching removes a layer of paint in the keytop surface to either expose the base colour or a secondary layer of ink and is often used to create Legends often used to expose areas to be backlight.

Epoxy Keytops

Epoxy Coating deposited on the top surface of the key provide a harder surface (not recommended for outdoor applications as not UV resistant).

Polyurethane / Silicone Coating

A wear resistant clear spray coating is applied to provide added chemical and wear resistance to painted surfaces and can have either a matt or gloss finish. Polyurethane coating provides the longer life with a silky-smooth texture when compared to the silicon clear coating which has a similar feel to the base material.

Wear resistance is tested using an RCA machine which is an abrasive tape test wear machine developed to test the abrasion performance and resistance to wear in accordance with international test standards ASTM F2357-04 & ASTM F2357-10.

Design Considerations

SNAP RATIO

The snap ratio of a keypad is directly linked to the tactile feel experienced by the user. Designers should attempt to maintain ratios of around 40-60% only dropping below this if they are prepared to compromise

tactile to ensure longer life. Snap ratio is measured as $F1-F2$ divided by $F1$, where $F1$ is the actuation force and $F2$ is the contact force. See figure 3.

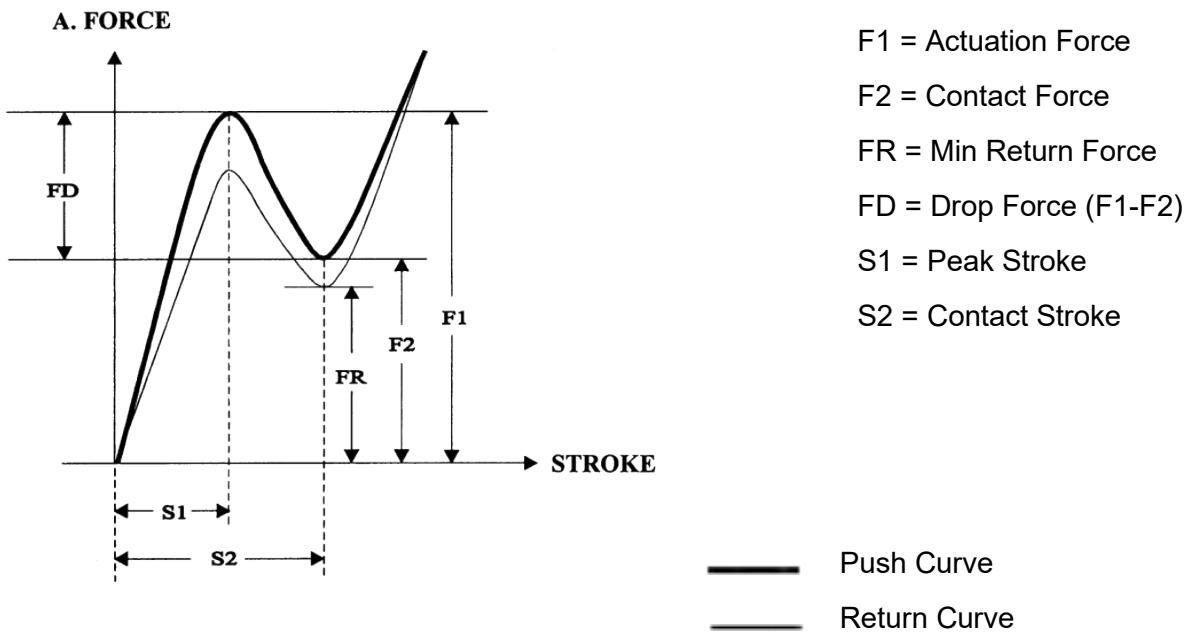

Fig 3 – Snap Ratio

TACTILE FEEDBACK

The keypad shape and size of any rubber keypad can be designed to achieve almost any combination of actuation force and tactile response via a collapsing web. Most applications simply require a positive tactile feel with a long life and as such an actuation force of 125 ~ 150g, with an accompanying snap ratio of 40 ~ 60% is a good recommendation.

Variations in tactile response can be achieved with various combinations of contact stroke, actuation force, key shape, and material hardness. More specific guidelines are difficult to lay down. However, if a customer specifies key size, actuation force and stroke, Diamond can assist in the design to achieve the required parameters. Always remember to specify higher actuation force for wider or taller keys. Tactile feedback can also be achieved using metal domes as part of an assembly, these are often attached to the underside of the keypad and the web simply acts as a hinge.

A common problem with rubber keypad design is ensuring that the rocking action that can be a feature of a switch design is minimised. The following suggestions will assist in reducing the problem. Return force should also be set at around 30 ~ 35g to ensure that keys do not stick.

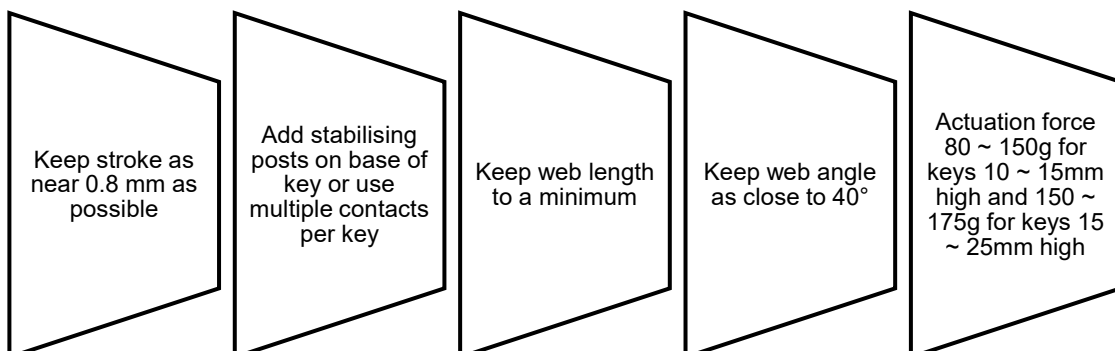

SWITCH LIFE

Keypad style and the durometer of the material are the factors that most effect switch life. Using a higher durometer silicone, increasing the actuation force or by increasing the stroke will all decrease life. See fig 4.

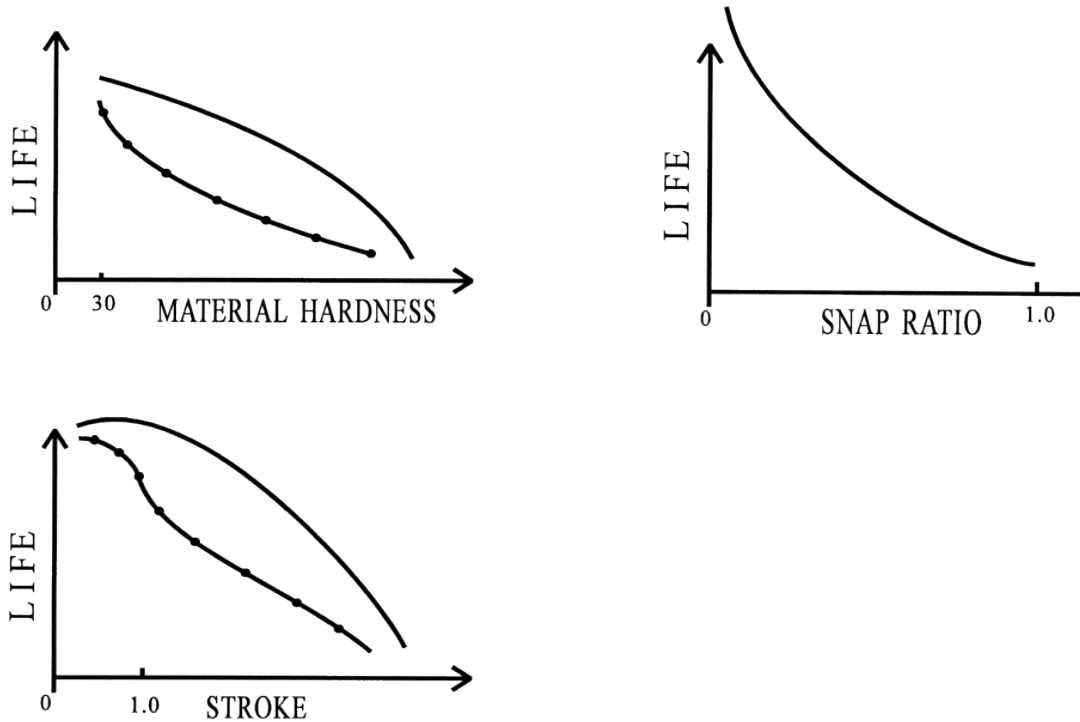

Fig 4 – Switch life

MINIMUM KEY HEIGHT

This can be calculated for any design from:

Keypad base thickness + bezel thickness + stroke of key + 0.5mm

It is worth remembering if the keytop is very thin depending on the durometer chosen it may deflect.

CONDUCTIVE SWITCH CONTACTS

We offer different types of contact solutions, each with its own unique characteristics.

Carbon Pills are most used due to their long life (>30 million ops) low resistance (<150 Ω with 100g load), High quality and low cost. The pill shape most used are circular with diameters ranging from 2.0 ~ 8.0mm and thickness from 0.3 ~ 0.8mm. They also come in different shapes such as Oval and annular and in various sizes an example of which is shown in fig 5 below, please check availability with our team before choosing as new shapes may become available and others removed based on popularity.

Thickness Diameter	0.3-0.4 mm	0.3-0.4 mm	0.4-0.5 mm	0.4-0.5 mm	0.5-0.8 mm	0.5-0.8 mm
	Texture	Flat	Texture	Flat	Texture	Flat
2.0 mm	130	110	120	120	110	75
2.5 mm	120	100	120	100	100	80
3.0 mm	80	60	70	50	60	50
3.5 mm	60	50	50	40	50	40
4.0 mm	60	50	40	40	35	30
4.5 mm	55	40	40	40	35	30
5.0 mm	55	40	40	30	30	30
5.5 mm	50	40	30	30	30	30
6.0 mm	50	40	30	30	30	30
6.5 mm	50	40	30	30	30	30
7.0 mm	50	40	30	30	30	30
8.0 mm	50	40	30	30	30	30

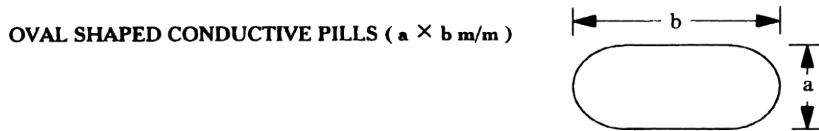

1.5 × 5	2 × 5	2.5 × 4	2.5 × 11	3 × 8	4 × 8	4 × 15	5 × 7
2 × 3.5	2 × 6	2.5 × 5	3 × 5	4 × 6	4 × 11	4 × 16	5 × 14
2 × 4.5	2 × 12	2.5 × 6	3 × 5.5	4 × 7	4 × 14	4.5 × 8	6 × 10

Fig 5 – Oval shaped conductive pills

ANNULAR SHAPED CONDUCTIVE PILL

External Diameter 8mm with an internal diameter of either 4.06mm or 2.7mm other sizes may be available upon request.

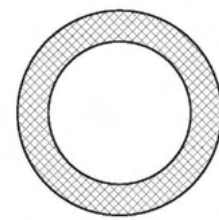

Circular Ring

Printed Carbon Contacts are an alternative solution when your required shape is not available, or a lower cost break is required. These are simply created by either printing or dipping the contact area with 10-20 microns of carbon ink, the resistance is far higher (<800Ω with 300g load) and they have a shorter lifespan (>1 million ops) and are less suitable for harsh environments their main advantage is being able to create a conductive surface on any shape however we would always recommend the use of carbon pills wherever possible as they offer a more robust solution.

Hard and Soft Gold Pills are available and tend to be specified for Automotive switching applications due to their low resistance and higher current handling capabilities. These are created by gluing a plated metal actuator to the switch actuator.

METAL SWITCH DOMES

These come in a wide range of shapes and sizes from 6mm Diameter to 20mm Diameter and from 150g to 2250g operating force and can be simply stainless steel, Nickel or Gold Plated although the most commonly used are between 8.4mm and 12.2mm Diameter and 150g to 400g operating force, they tend to have a very low travel typically 0.4mm to 0.7mm but provide a very good tactile response, below is an example of the construction.

The metal dome (Disc) can be supplied either attached to the keypad or on a separate disc array for the user to attach to their PCB and we would recommend using Hard Gold contact pads were possible to provide the greatest resistance to wear. Samples of metal domes are available on request.

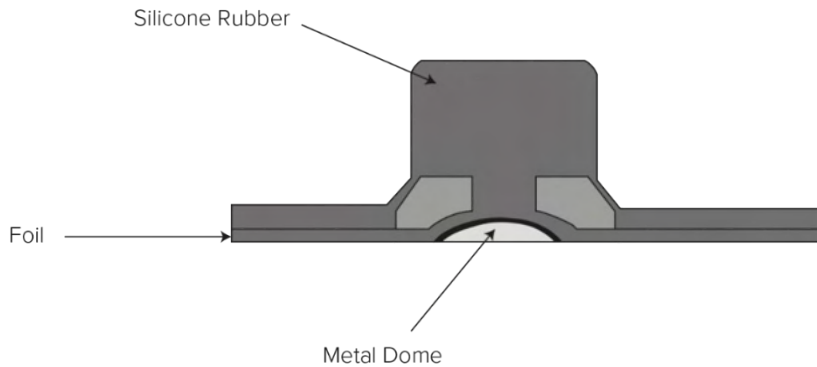

POLYESTER SWITCH DOMES

It is also possible to use polyester which has been embossed to create a tactile dome with a printed silver conductive pad on the underside. This only tends to be used where a low travel and low-cost solution is required, below is an example of this construction.

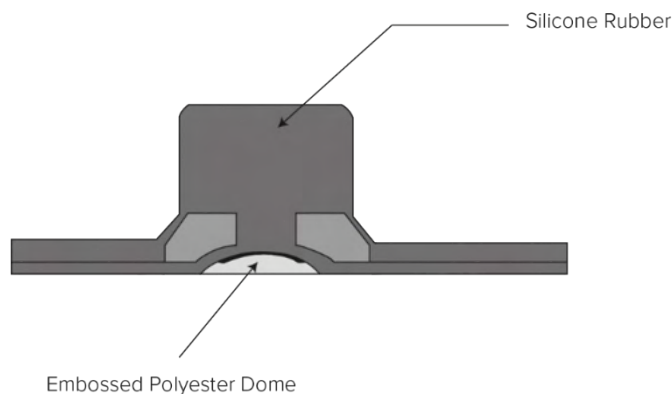

PRINTED CIRCUIT BOARD DESIGN

Rubber Keypad's themselves are very reliable in operation but when considering PCB design, the environment that the keypads are to be used in must be taken into consideration to ensure the complete switching unit remains reliable.

The choice of plating for the board is probably the most important factor and for keypads with carbon pills we recommend the following.

Gold plating over Nickel is the preferred choice with a recommended layer of 30-50 Micro inches of Gold over 100-200 Micro inches of Nickel to provide a contact resistance of <100 Ω. If Nickel plating is to be used without gold, then a minimum plating thickness of 200 Micro inches is recommended.

When designing shorting pads for carbon pills we would recommend a track width of 0.5mm and separation gap of 0.6mm, always attempt to get as many shorting paths as possible to increase switch reliability and ensure that the pad size is never smaller than the carbon pill by a minimum of 1.25 times.

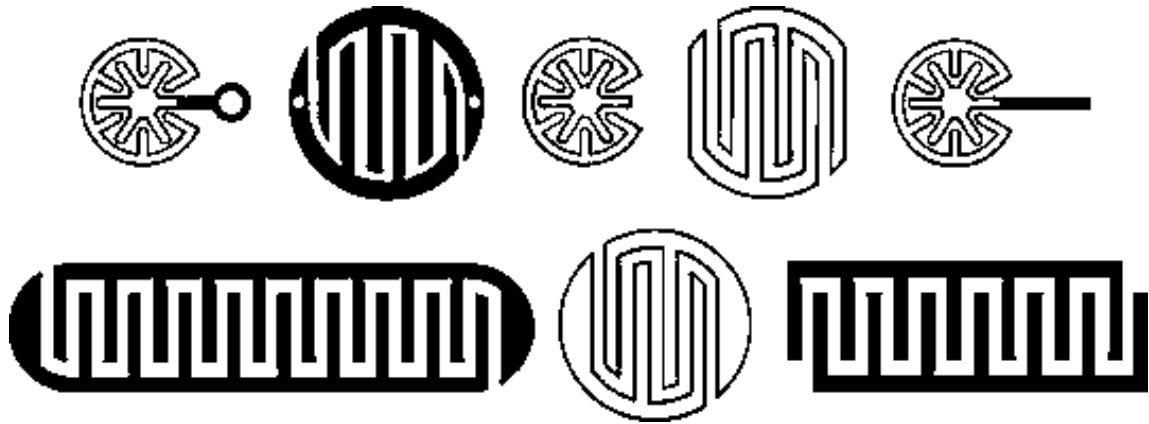
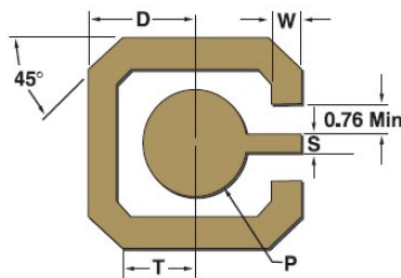

Fig 6 – Examples of Switch Pad Designs

Diameter	“D”	“T”	“W”	“P”	“S”
5 mm	2.59	1.67	1.04	2.03	0.38
6 mm	2.96	1.96	1.09	2.45	0.64
7 mm	3.45	2.28	1.27	2.86	0.76
8.5 mm	4.19	2.77	1.55	3.48	0.92
10 mm	4.67	3.15	1.55	4.08	1.10
12 mm	5.59	3.76	1.85	4.90	1.30
12.2 mm	5.72	3.86	1.85	4.90	1.30
14 mm	6.40	4.34	1.98	5.70	1.60
16 mm	7.32	4.98	2.26	6.50	1.60
18 mm	8.32	5.61	2.54	7.00	1.90
20.2 mm	9.04	6.17	2.54	7.00	1.90

Metal Domes come in a range of shapes and sizes and the plating of which is essential to prevent deterioration of the contact pad over time, below is a guide to assist with this and we recommend life testing your specific application prior to production.



Vent hole through the board is suggested.

GOLD

Electro-Deposited Gold, Hard
 (Ref – MIL-G-45204C, Type II, Grade C)
 < 1,000,000 cycles life: 0.000015" – 0.00003" thick
 (15 – 30 micro inches or 0.38 – 0.76 microns)
 > 1,000,000 cycles life: 0.00003" – 0.00005" thick
 (30 – 50 micro inches or 0.76 – 1.27 microns)

NICKEL

Electro-Deposited Nickel, Bright Hard
 < 1,000,000 cycle life: 0.00005" – 0.0002" thick (50-200 micro inches or 1.25 – 5.0 microns)
 > 1,000,000 cycles life: 0.0002" – 0.0005" thick (200-500 micro inches or 5.0 – 12.5 microns)

ALIGNMENT FEATURES

When designing the keypad some thought must be put in as to how you will ensure the keys are central to the fascia aperture and the contact pads on the PCB. This can be achieved by creating alignment holes in the keypad base for the fascia and PCB. It is also possible to add pull throughs which ties the keypad to a hole in the PCB, below is an example of a pull through, these can be designed in various shapes and sizes, contact Diamond HMI Product Support Team for further assistance.

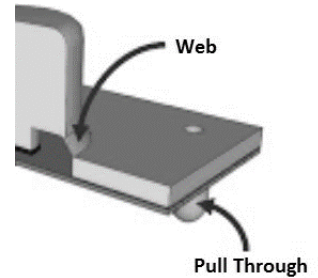

DIMENSIONAL TOLERANCES

Because silicone is a highly elastic material and subject to manufacturing variations in Moulding conditions and material compounding, careful consideration should be given to the tolerance tables below. If a large area is to have keys fitted, it is often advisable to split the keys up and design the keypad as a set which can be separated and fitted into different sections to maintain a reasonably tight tolerance.

Dimension (mm)	General (± mm)	Precise (± mm)
<10	0.1	0.1
10~19.9	0.15	0.15
20~29.9	0.2	0.15
30~49.9	0.3	0.25
>50	0.60%	0.40%

ACTUATION FORCE

Design Force (g)	General (± g)	Precise (± g)
40 ~ 59	15	10
60 ~ 79	20	15
80 ~ 99	25	20
100 ~ 150	30	25
>150	25%	20%

MECHANICAL DRAWINGS

A sample mechanical drawing is shown below. To assist our designers please ensure that where possible the information shown is included in any 2D drawings, 3D drawings can of course be measured by ourselves. We can work with most common 3D file formats such as .IGES, .SLDPRT, .STP as well as .DWG and .DXF. We prefer artwork in .AI, .CDR or .EPS format, if you require assistance in having a 3D diagram produced, we can also assist you with this.

Once commissioned to make the tooling with samples we will generate a set of Drawings with any modifications required for production and tactile response, which a full set will be supplied for approval and your records before we commence tooling and sample manufacture.

Overall Keypad Size
Base Thickness
Keytop Outside Dimensions
Overall Key Heights
Contact Size
Mounting Hole Details
Pull Through Details
Dimensions
Key Stroke / Travel length
Keypad / Button Colour references such as Pantone, BS, RAL or we can colour match a sample
Actuation Force in grams
Snap Ratio
Electrical Specs
Material Specs Inc Surface Coating
Shore Hardness
Printing Artwork

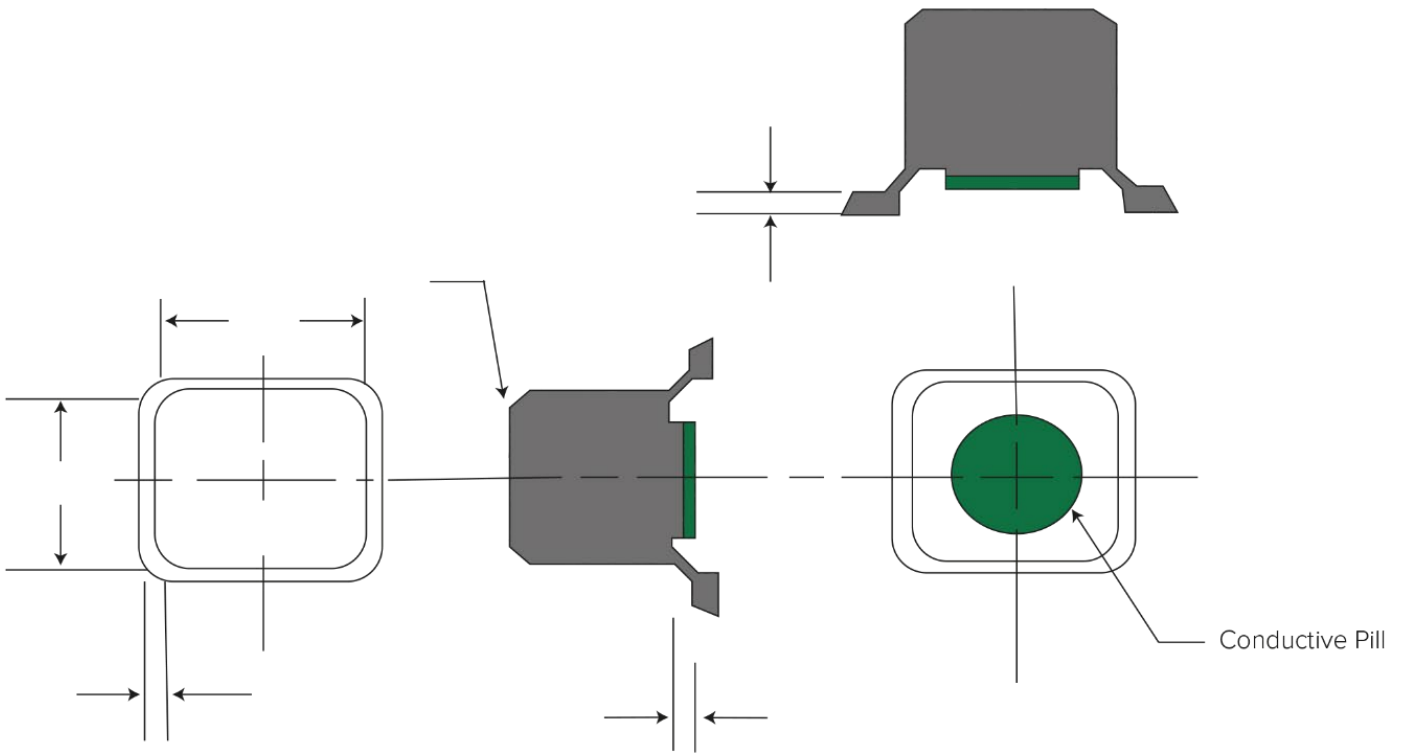

View A

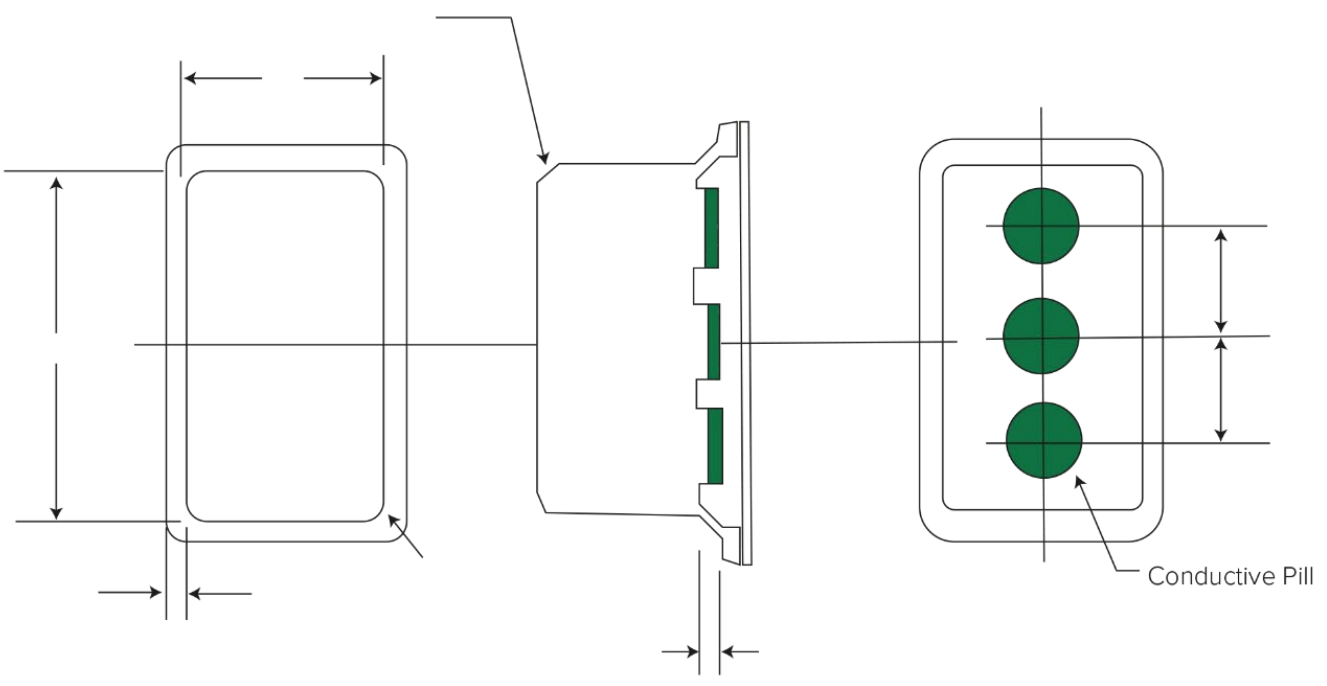

View B

Below is an example of a custom keypad drawing, it does not specify all the dimensions as it is simply the 2D drawing created from a 3D Design. If you cannot supply a 3D Design, we can create this for you as part of our design services using your drawings for reference.

The diagrams below are a guide to assist in the overall product design.

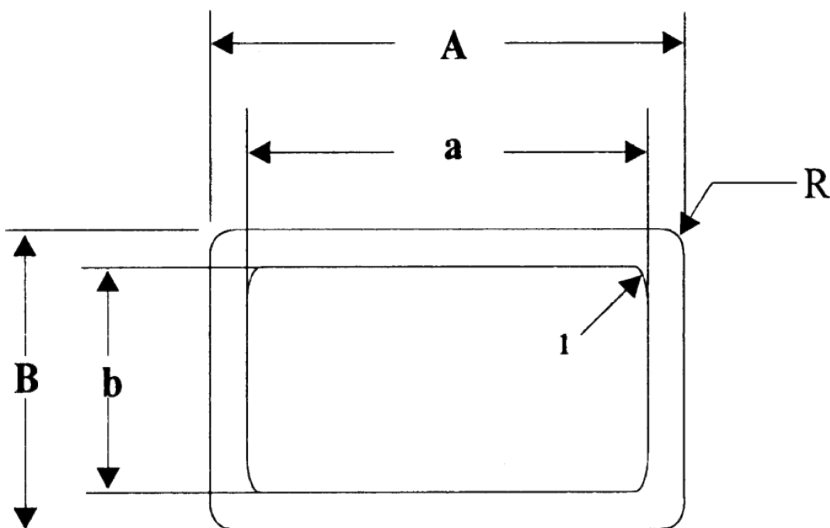
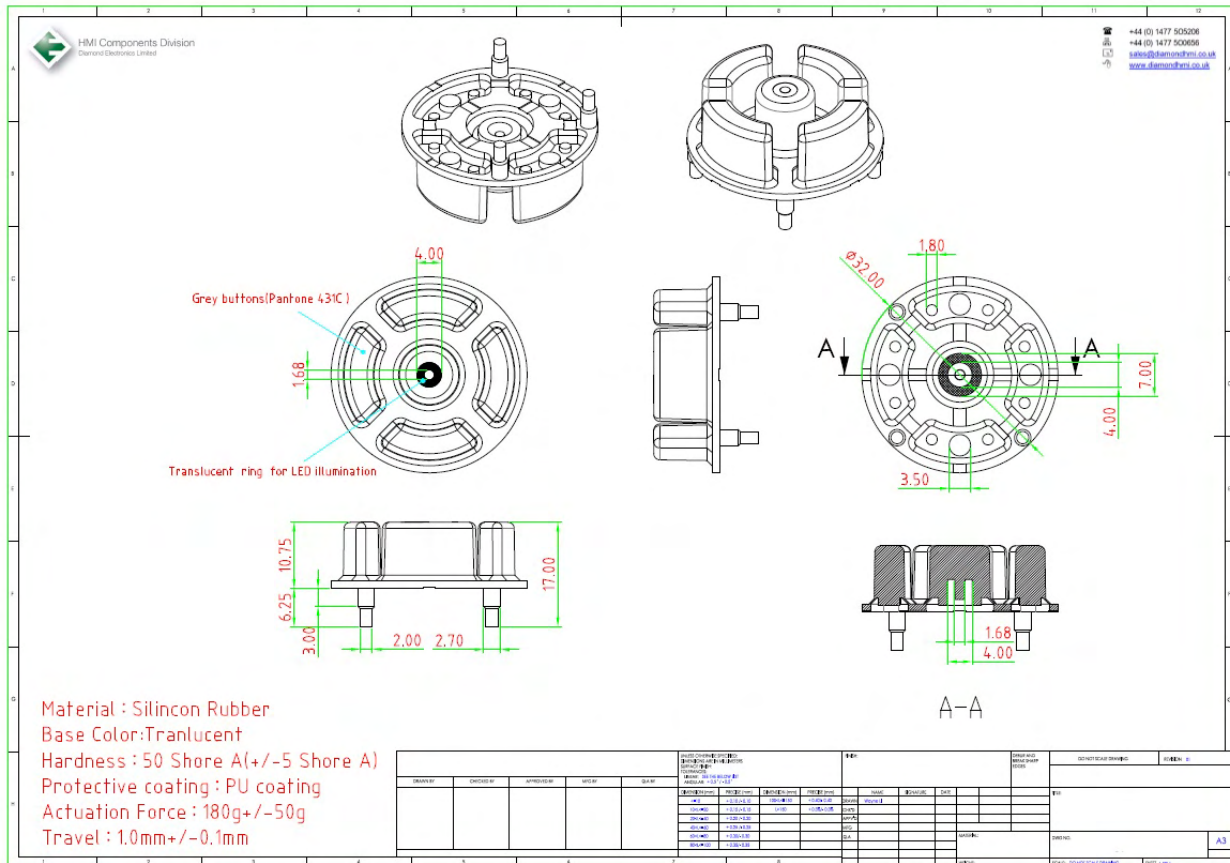

A & B = Plastic Case Dimensions a & b = Rubber Dimensions

A – a ≥ 0.4 mm

B – b ≥ 0.3 mm

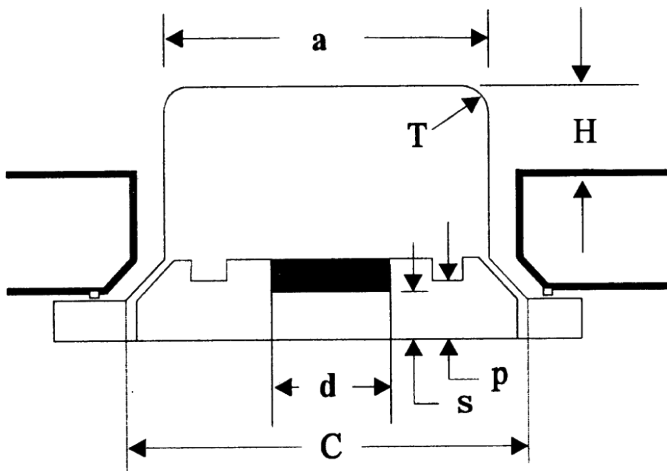

H = Height of Key Above Plastic S = Stroke of Key

P = Stroke of Stop Bar $H - S \geq 1.0$ mm

$A - d \geq 1.5$ mm

$P - S \geq 0.15$ mm

C = Width of Web Base Typically

2.0 mm More Than "a"

R = Minimum Radius for Side Edges of Key Is 0.2 mm

T = Minimum Radius for Top Edges of Key Is 0.2 mm

CONDITIONS FOR THE DESIGN OF A RUBBER KEY

		Force Range	0 - 350 grams			Force Range	30 - 80 grams
		Stroke Range	0.5 - 3 mm			Stroke Range	2.0 - 4.0 mm
		Life Cycle (10^3)	500 - 2000			Life Cycle (10^3)	5000 - 20,000
		Typical Uses	Telephone, remote control, automotive, radio, toys, calculators			Typical Uses	Computer and typewriters
		Force Range	30 - 250 grams			Force Range	30 - 200 grams
		Stroke Range	0.7 - 1.5 mm			Stroke Range	1.0 - 2.5 mm
		Life Cycle (10^3)	500 - 2000			Life Cycle (10^3)	500 - 3000
		Typical Uses	Telephone, remote control, games, toys, calculators			Typical Uses	Telephone, typewriter and test equipment
		Force Range	0 - 350 grams			Force Range	20 - 80 grams
		Stroke Range	0.5 - 3 mm			Stroke Range	0.2 - 1 mm
		Life Cycle (10^3)	500 - 2000			Life Cycle (10^3)	500 - 10,000
		Typical Uses	Telephone, remote control, office machines, measuring instruments, toys,			Typical Uses	Remote control, calculator, computer and typewriter

EXAMPLE DESIGNS FOR RUBBER KEYS

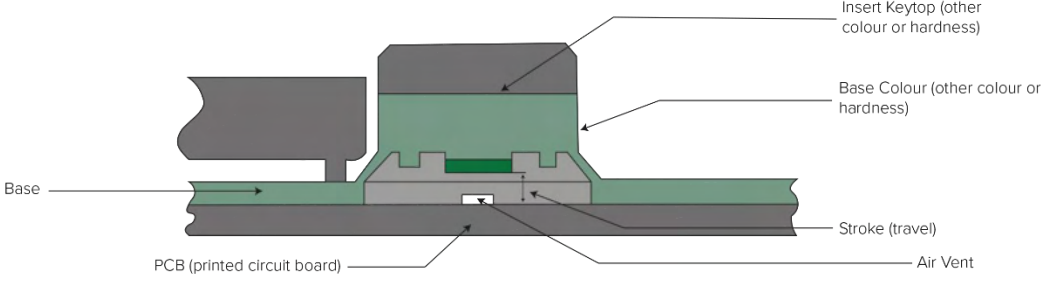
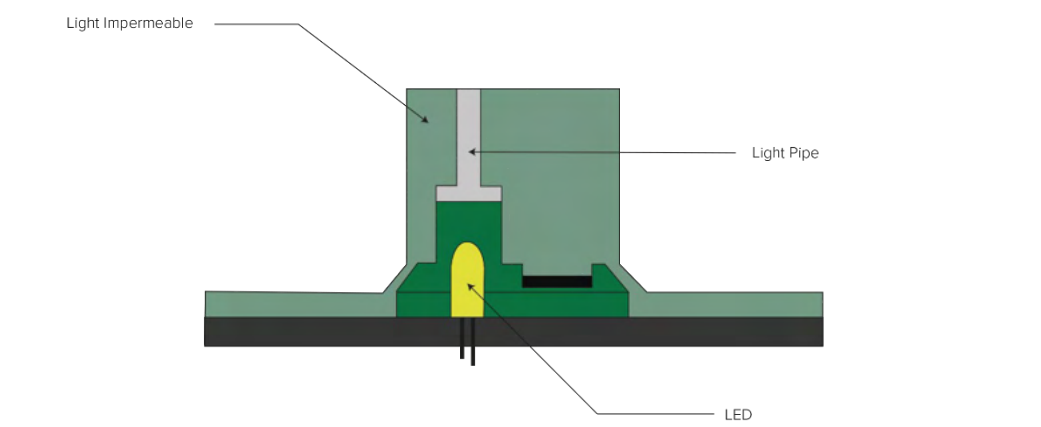
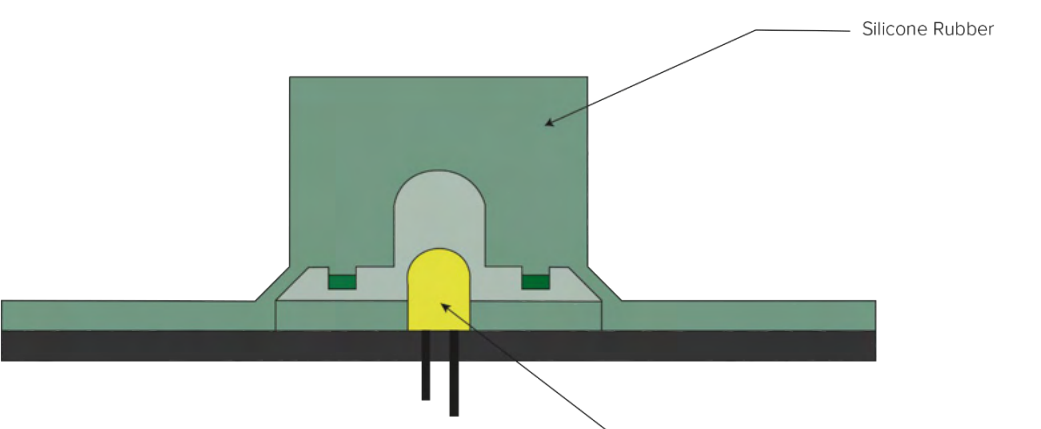
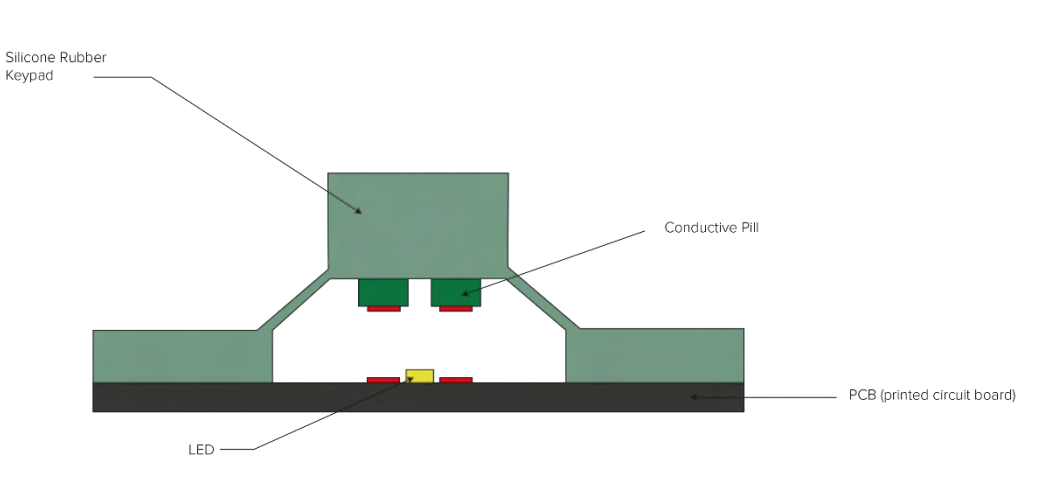
<p>Different shore hardness and colour in the basic keypad and key.</p>	 <p>Labels: Insert Keytop (other colour or hardness), Base Colour (other colour or hardness), Base, PCB (printed circuit board), Stroke (travel), Air Vent.</p>
<p>Square key top design with integrated light pipe.</p>	 <p>Labels: Light Impermeable, Light Pipe, LED.</p>
<p>Centre Illuminated Key.</p>	 <p>Labels: Silicone Rubber, LED.</p>
<p>Construction for backlit key.</p>	 <p>Labels: Silicone Rubber Keypad, Conductive Pill, LED, PCB (printed circuit board).</p>

<p>Base colours.</p>	<div data-bbox="523 264 1008 568" data-label="Image"> </div> <p>Multi coloured keys can be achieved by blending different opaque coloured pigments into the silicon material as well as using translucent materials for light diffusion. This can be loaded into different sections of a mould resulting in different key colours with a bleed between the keys which is then covered by a bezel. This is a lower cost of achieving different key colours without the need to make a separate tool to produce separate coloured key tops although there are limitations to the distance between keys due to the bleed, please see the example below and contact our team to establish if this is feasible within your design.</p>
<p>Utilising.</p>	<div data-bbox="491 810 1129 1093" data-label="Image"> </div> <p>Utilising a 2-shot process we can also produce keypads where the base material is a solid opaque colour and the keys translucent, this is particularly useful when you wish to illuminate the buttons individually as the solid base colour inhibits light bleed between keys, an example of this is shown below.</p>

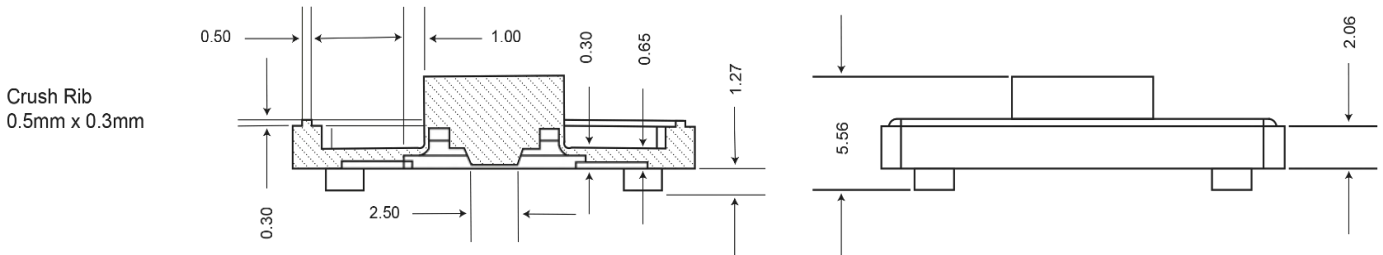

Printing

Keypads can be spray painted and laser etched, screen printed or a combination of both spray and screen printing. It is possible to have concave or convex keytops (average maximum curvature for screen printing 0.3mm depending on size) please contact our team who can advise on the most suitable method of printing on your design, below are various guides and examples of what can be achieved.

Positive Printing

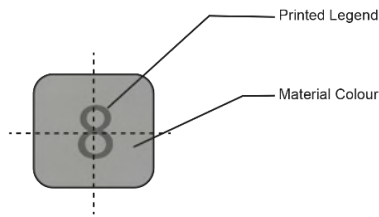

Legend off-centre: ± 0.3 mm
Line width: ≥ 0.2 mm

Negative Printing

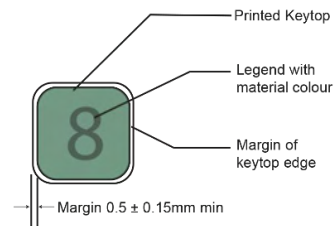

The legend, the margin of the keytop edge and the key flank are illuminated by use of transmissive material

LASER-ETCHED LEGENDS (L/C Keytops)

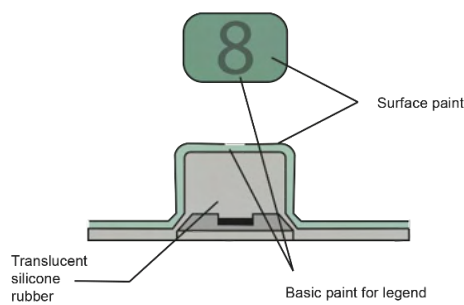

EPOXY COATED KEYTOPS

This produces a hard key surface by applying small amount of clear epoxy resin onto the keytop surface, the resulting height of the coating is dependent on the size of the surface area to be coated and cannot be stipulated during the design process as it is simply achieved by applying a viscous epoxy over the surface and the surface tension of the material holds it in place whilst it is either air or UV cured. This option is not recommended for outside use as the materials used are not UV stable and the clarity of the resin will degrade when exposed to an external light source.

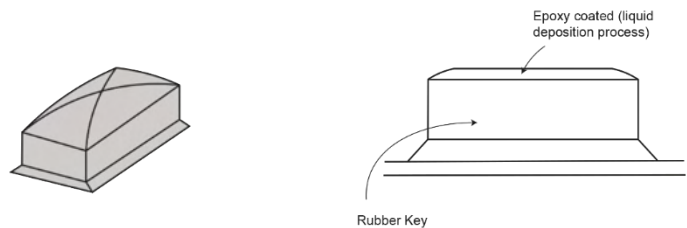

POLYURETHANE / SILICONE COATING

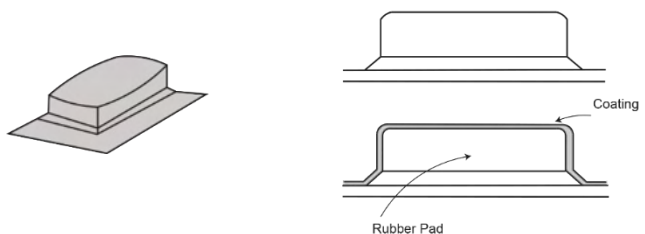

PLASTIC KEYTOPS

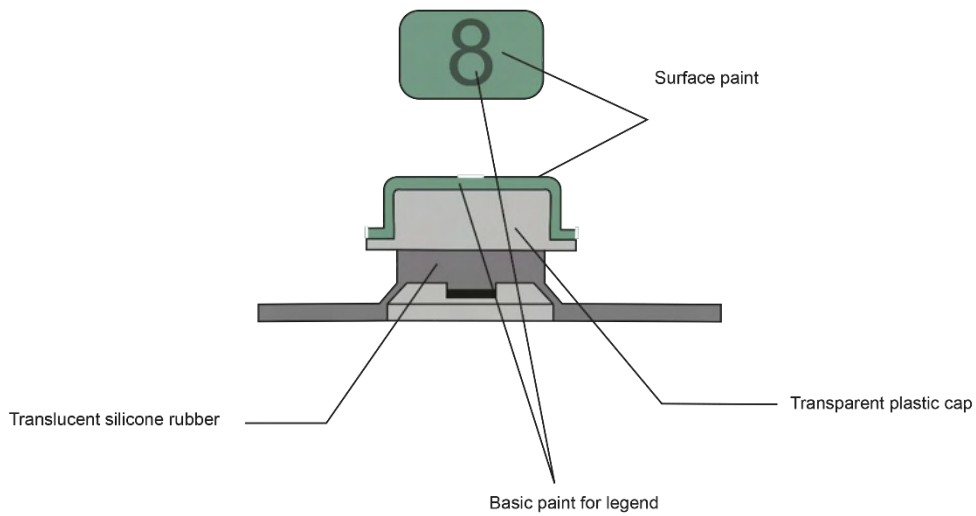

PROCESS OVERVIEW

Silicone keypads are produced by compression moulding, this is where the charge (Silicone) is compressed between 2 heated steel plates and the material vulcanises through time and pressure.

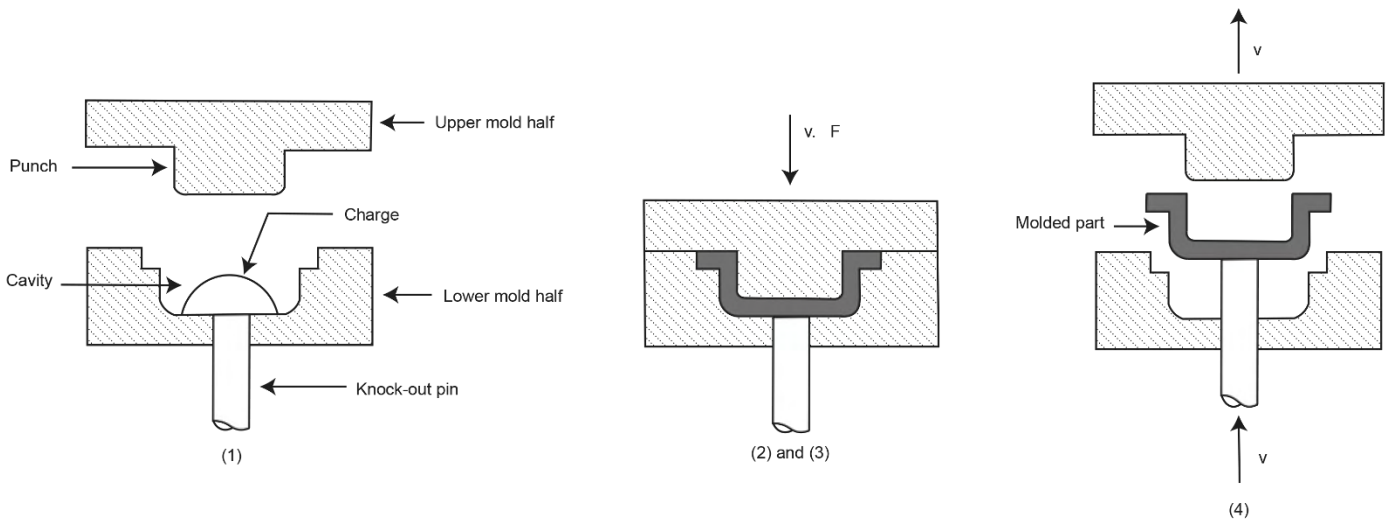

Tools are made of multi-cavities to optimise production and lower cost and the lower the volume of material to be cured the quicker the cure time, it is also worth noting that the tools must be in balance.

It is worth noting that the tools are designed with a compensation factor to allow for shrinkage based on the specific shore hardness of silicon required and it is not possible to change shore hardness without this adversely affecting the components size, often if the customer wishes to change shore hardness a new tool may be required.

To further assist our customers to understand and specify a suitable key action, Diamond HMI has produced a [Rubber Keypad Design Tool](#) which has examples of many combinations of Key Travel, Tactile Response and Shore Hardness's including examples of Membrane and Rubber combinations used in our CombiKey products. Please contact us to request this free tool on +44 (0)1477 505206 or email sales@diamondhmi.co.uk.